

# Model ES SERIES

## ELECTRIC SCISSOR LIFTS



### Performance

Platform Height—Elevated		
1930ES	18 ft 9 in.	5.72 m
2030ES	20 ft	6.10 m
2630ES	25 ft 6 in.	7.77 m
2646ES	26 ft	7.92 m
3246ES	31 ft 9 in.	9.68 m
Platform Capacity		
1930ES	500 lb	227 kg
2030ES	800 lb	363 kg
2630ES	500/800 lb	227/363 kg
2646ES	1,000 lb	454 kg
3246ES	700/1,000 lb	318/454 kg
Capacity on Platform Extension	250 lb	113 kg
Lift/Lower Time		
1930ES	26/30 seconds	
2030ES	28/40 seconds	
2630ES	33/37 seconds	
2646ES	41/50 seconds	
3246ES	55/62 seconds	
Maximum Drive Height		
	Fully Elevated	
Weight*		
1930ES	2,685 lb	1,218 kg
2030ES	3,830 lb	1,737 kg
2630ES	4,750 lb	2,155 kg
2646ES/ 3246ES	4,945 lb	2,243 kg
Ground Bearing Pressure		
1930ES	109 psi	7.66 kg/cm <sup>2</sup>
2030ES	81 psi	5.69 kg/cm <sup>2</sup>
2630ES	90 psi	6.32 kg/cm <sup>2</sup>
2646ES/ 3246ES	87 psi	6.11 kg/cm <sup>2</sup>
Drive Speed—Elevated		
	0.5 mph	0.8 km/h
Drive Speed—Lowered		
1930ES	3.0 mph	4.82 km/h
2030ES/ 2630ES	2.75 mph	4.43 km/h
2646ES/ 3246ES	2.50 mph	4.00 km/h
Gradeability		
	25%	
Turning Radius (Inside)		
	Zero	
Turning Radius (Outside)		
1930ES	69 in.	1.75 m
2030ES/ 2630ES	81 in.	2.06 m
2646ES/ 3246ES	95.1 in.	2.41 m

\* Certain options or country standards will increase weight.

### Standard Specifications

#### Power Source

Batteries	4x6V, 220 amp-hr	
Charger	20 Amp Automatic	
Drive	24V Electric	8hp

#### Hydraulic Reservoir

Capacity		
1930ES/2030ES/2630ES	1.25 gal.	4.73 L
2646ES/3246ES	1.7 gal.	6.4 L

Pump	Fixed Displacement Gear	
------	-------------------------	--



#### Tires

Tire Size/Type	
1930ES/2030ES/2630ES	12.5 x 4 in. Non-Marking Solid
2646ES/3246ES	16 x 5 in. Non-Marking Solid

#### Brakes

Electric/Friction

### Standard Features

- Proportional Controls
- Drywall Gate<sup>1</sup>
- Fold-Down Guard Rails<sup>2</sup>
- Slide-Out Battery Trays
- All Motion Alarm
- Horn
- Manual Descent Pull Cable
- Lanyard Attach Points
- Powder-Coated
- Nickel Plated Pins
- Scissor Maintenance Prop
- Machine Tie Downs
- 36 in. (91 cm) Roll-Out Deck Extension<sup>3</sup>
- Four 6V, 220 Amp-Hour Deep Cycle Batteries
- Industry Leading Duty Cycles
- Battery Condition Indicator
- 110V-AC Receptacle in Platform
- Automatic Traction Control (ATC)
- 20 Amp Automatic SCR Charger
- Hourmeter
- Tilt Alarm and Light
- Moveable, Removable Platform Control Console with Rail Mounting Bracket
- Lubrication Free Scissor Arm Bushings
- Mechanized Pothole Protection
- Fork Lift Pockets, Lift from Side and Rear
- 50 in. (1.27 m) Roll-Out Deck Extension<sup>4</sup>

1. Not included on 1930ES. 2. Optional on 1930ES. 3. 1930ES, 2030ES and 2630ES. 4. 2646ES and 3246ES.

### Accessories & Options

- Spring-Loaded Gate
- 245 Amp-Hour Batteries<sup>5</sup>
- Lifting Lugs
- Platform Padding
- 1/2 in. Airline
- Nite Bright<sup>8</sup>
- Special Hydraulic Oils
- Flashing Amber Beacon
- 1,000W-AC Inverter
- UL<sup>®</sup> EE Rating<sup>6</sup>
- Platform Padding with Proximity Switches
- Quik Welder Prep Package<sup>7</sup>
- 220 Amp-Hour AGM Batteries<sup>9</sup>
- Accessory Packages:
  - Electrician's Package
  - JLG<sup>®</sup> Workstation
  - Pipe Rack Accessory<sup>5</sup>
  - Plant Maintenance Package
  - Plumber's Package
  - Panel Carrier Accessory<sup>5</sup>
  - Quick Welder<sup>®</sup> Package

5. Not available on the 1930ES. 6. Not available with AGM Batteries. 7. Includes power cable for welder and fire extinguisher. 8. Includes two platform mounted worklights. 9. Not available on EE rated units.

# Model ES SERIES

ELECTRIC SCISSOR LIFTS

## Dimensions

All dimensions are approximate.

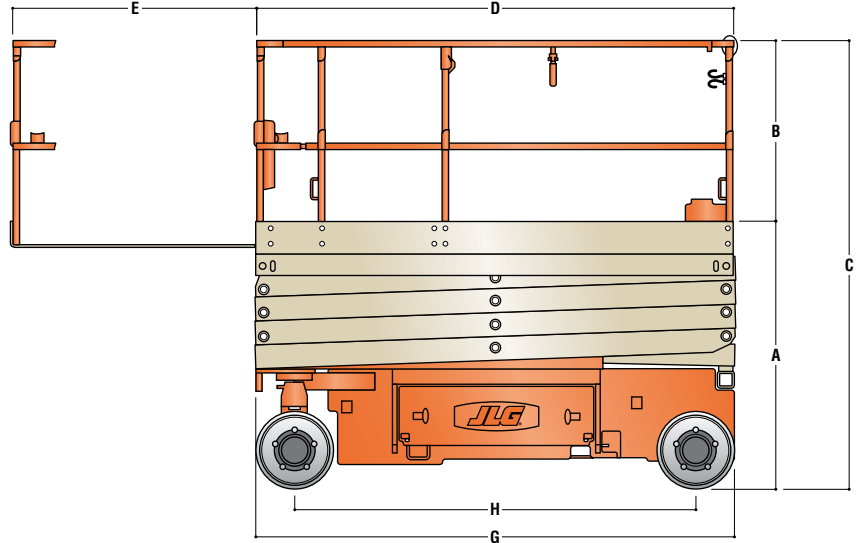
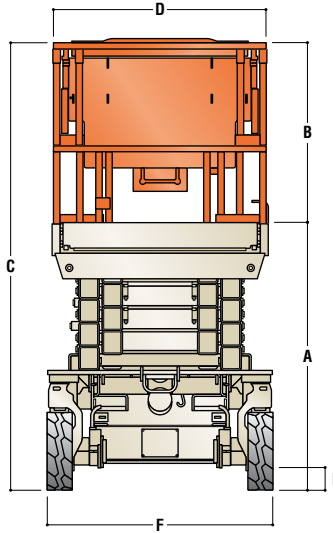

### A. Platform Height-Lowered

1930ES	34 in.	0.86 m
2030ES	43.5 in.	1.10 m
2630ES	48.5 in.	1.23 m
2646ES	49.5 in.	1.26 m
3246ES	49.5 in.	1.26 m

### B. Platform Railing Height

43.3 in. 1.10 m

### C. Overall Height-Rails Lowered

1930ES	N/A	
2030ES	5 ft 11.5 in.	1.80 m
2630ES	6 ft 4.5 in.	1.94 m
2646ES/3246ES	6 ft 5.5 in.	1.97 m

### D. Platform Size

1930ES	30 x 73.5 in.	0.76 x 1.87 m
2030ES/2630ES	30 x 90.5 in.	0.76 x 2.3 m
2646ES/3246ES	44 x 98.5 in.	1.12 x 2.5 m

### E. Platform Extension

1930ES/2030ES/2630ES	35.5 in.	0.9 m
2646ES/3246ES	50 in.	1.27 m

### F. Overall Width

1930ES/2030ES/2630ES	30 in.	76 cm
2646ES/3246ES	46 in.	1.17 m

### G. Overall Length

1930ES	6 ft 1.5 in.	1.87 m
2030ES/2630ES	7 ft 6.5 in.	2.3 m
2646ES/3246ES	8 ft 2.5 in.	2.5 m

### H. Wheelbase

1930ES	5 ft 3 in.	1.6 m
2030ES/2630ES	6 ft 2 in.	1.88 m
2646ES/3246ES	6 ft 10 in.	2.09 m

### I. Ground Clearance

1930ES/2030ES/2630ES	3.5 in.	8.8 cm
2646ES/3246ES	5 in.	12.7 cm



## The JLG "1 & 5" Warranty

JLG Industries, Inc. backs its products with its exclusive "1 & 5" Warranty. We provide coverage on all products for one (1) full year, and cover all specified major structural components for five (5) years. Due to continuous product improvements, we reserve the right to make specification and/or equipment changes without prior notification. This machine meets or exceeds applicable OSHA Regulations in 29 CFR 1910.67, 29 CFR 1926.453, ANSI A92.5-2006, and CSA Standard CAN3-B354.2-M82, as originally manufactured for intended applications.

Form No.: SS-ES-908  
Part No.: 3131580  
R111204  
Printed in USA

**JLG Industries, Inc.**  
1 JLG Drive  
McConnellsburg, PA 17233-9533  
Telephone 717-485-5161  
Toll-free in US 877-JLG-LIFT  
Fax 717-485-6417  
[www.jlg.com](http://www.jlg.com)

**An Oshkosh Corporation Company**