



octopussy classic

ITA

ENG

ESP

FRA

**OIL & STEEL**  
AERIAL PLATFORMS



# octopussy classic

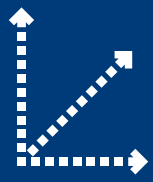

super compatta

super compact

súper compacta

super compacte

ITA

La nuova **Octopussy classic** è **estremamente compatta**: solo 78 cm di larghezza e 1,9 m di altezza in movimento.

Queste caratteristiche permettono alla piattaforma di passare attraverso una comune porta domestica o comunque all'interno di spazi estremamente ristretti ed angusti.

ESP

La nueva **Octopussy classic** es **extremadamente compacta**: sólo 78 cm de anchura y 1,9 m de altura en movimiento. Estas características permiten a la plataforma pasar a través de una común puerta doméstica o, en todo caso a través de espacios extremadamente restringidos y limitados.

ENG

The new **Octopussy classic** is **extremely compact** - just 78 cm wide and 1.9 m high when moving.

These features mean the platform can be driven through the doorway of a house or any other very narrow or confined space.

FRA

La nouvelle **Octopussy Classic** est **extrêmement compacte** : 78 cm de largeur seulement et 1,9 m de hauteur en mouvement. Ces caractéristiques permettent à la plateforme de passer par une porte domestique normale ou, dans tous les cas, dans des espaces extrêmement étroits et exigus.



octopussy classic

ITA

**Octopussy classic** è dotata di serie di un **innovativo carro cingolato, allargabile idraulicamente**, che facilita e rende più sicure le attività di carico/scarico da autocarro tramite rampe ed inoltre rende più stabile la piattaforma in caso di spostamenti off road.

ENG

The **Octopussy classic** is equipped as standard with an **innovative, hydraulically-extendible tracked truck**, which facilitates loading/unloading from the truck via ramps and also increases platform stability during off-road manoeuvres.

ESP

**Octopussy classic** está equipada de serie con un **innovador carro de orugas, ensanchable hidráulicamente**, que facilita y confiere mayor seguridad a las actividades de carga/descarga en y desde camión mediante rampas, además de otorgar mayor estabilidad a la plataforma en los casos de desplazamiento off road.

FRA

L'équipement de série **d'Octopussy Classic** prévoit un **chariot chenillé innovateur, qui s'élargit grâce à un système hydraulique**, ce qui facilite et assure une plus grande sécurité lors des activités de chargement/déchargement du camion à l'aide de rampes. La plateforme est également beaucoup plus stable dans le cas de déplacements off road.

facilità di movimentazione

easy to handle

facilidad de desplazamiento

facilite de manutention



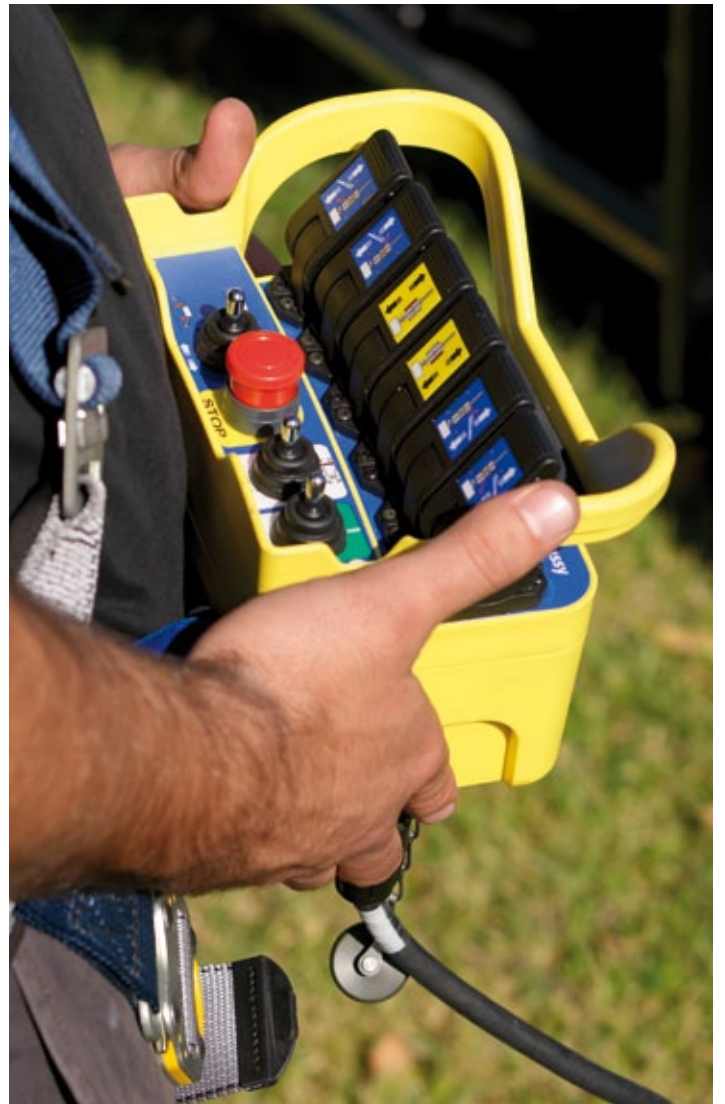

maggior sicurezza operativa

better operating safety

mayor seguridad operativa

une plus grande securite  
durant le travail

ITA

Grazie ai nuovi sistemi di comando **tramite filocomando o radiocomando** (optional) l'operatore ha la possibilità di manovrare la piattaforma evitando di trattenersi nell'area operativa della stessa; in questo modo l'operatore gode di una maggiore sicurezza operativa nell'utilizzo della **Octopussy classic**.

ENG

Thanks to the new **remote control** systems (**either wired or radio-controlled**), the operator can manoeuvre the platform without standing in its range of action; this means better operating safety for the operator during use of the **Octopussy classic**.

ESP

Gracias a los nuevos sistemas de gobierno **mediante mando de cable o radiomando** (opcional), el operador puede maniobrar la plataforma sin permanecer en el área operativa de la misma; de esta forma el operador goza de mayor seguridad laboral durante el uso de la **Octopussy classic**.

FRA

Grâce aux nouveaux systèmes de commande par **commande à fil** ou bien **radiocommandés** (en option), l'opérateur a la possibilité de manoeuvrer la plateforme en évitant de rester dans la zone de travail de celle-ci. De cette manière, l'opérateur est plus en sécurité durant le travail lorsqu'il utilise l'**Octopussy Classic**.



#### ITA

**Octopussy classic** è disponibile in due versioni: **1401** e **1402**. Queste si differenziano per la diversa capacità di carico, 120 kg per la prima e 200 kg per la seconda.

Le due versioni hanno però identiche prestazioni, ben **14 m di altezza massima di lavoro** e **6,4 m di sbraccio massimo**.

La versione 1402 si differenzia dai principali concorrenti proprio per il vantaggio di permettere, con un carico di 200 kg sul cesto, l'utilizzo del jib idraulico.

#### ENG

**Octopussy classic** is available in two versions: **1401** and **1402**. The difference between the two lies in the loading capacity, i.e. 120 kg for the first and 200 kg for the second.

The two versions offer exactly the same performance though, **with an impressive max. work height of 14 m and an outreach of up to 6.4 m**.

The 1402 version differs from its main rivals in that it offers the advantage of allowing **use of the hydraulic jib** with a 200 kg load on the platform.

#### ESP

**Octopussy classic** está disponible en dos versiones: **1401** y **1402**. Estas versiones se diferencian por su diversa capacidad de carga, 120 kg la primera y 200 kg la segunda.

Sin embargo, ambas versiones ofrecen prestaciones idénticas, es decir, **14 m de altura máxima de trabajo** y **6,4 m de extensión máxima**.

La versión 1402 se diferencia de sus principales competidoras por la ventaja que significa permitir, con una carga de 200 kg en el cesto, **el uso del jib hidráulico**.

#### FRA

**Octopussy Classic** est disponible en deux versions : **1401** et **1402**. Chaque modèle possède une capacité de charge différente, 120 kg pour le premier et 200 kg pour le second.

Les deux versions offrent dans tous les cas les mêmes performances, à savoir, **14 m de hauteur maximum de travail** et **6,4 m d'allongement maximum du bras**.

La version 1402 se différencie des modèles proposés par la concurrence justement parce qu'elle a l'avantage de permettre **d'utiliser le jib hydraulique** avec une charge de 200 kg sur la nacelle.

elevate prestazioni

high performance

elevadas prestaciones

des performances elevees



# octopussy classic



ampia scelta di motorizzazione

wide range of power drive options

amplia elección de motorización

un vaste choix de motorisation

ITA

**Octopussy classic** può essere dotata a scelta di **motore benzina 13/15 cv** o **motore diesel**. Inoltre può essere scelto come opzionale il **motore elettrico 110/220 V** per effettuare interventi in ambienti chiusi senza emettere gas di scarico nocivi.

ENG

The **Octopussy classic** can be equipped with a **13/15 HP petrol engine** or **diesel engine**. Furthermore, the optional **110/220 electric motor** can be chosen for carrying out work indoors without noxious gas emissions.

ESP

A elección, **Octopussy classic** puede ser equipada con **motor gasolina 13/15 CV** o **motor diésel**. Además, como opcional se encuentra también disponible el **motor eléctrico 110/220 V** para efectuar intervenciones en ambientes cerrados evitando la emisión de gases de escape nocivos.

FRA

**Octopussy Classic** peut être équipée au choix d'un  **moteur à essence 13/15 cv** ou d'un  **moteur diesel**. De plus, il est possible de choisir en option le  **moteur électrique 110/220 V** pour effectuer des interventions dans des milieux fermés sans émission de gaz d'échappement nocifs.



octopussy classic

ITA

**Octopussy classic** è stata sviluppata per soddisfare le necessità di solidità e protezione dei dispositivi che nascono da applicazioni edili o florovivaistiche dove esiste il pericolo di danneggiamenti dovuti alla caduta accidentale di oggetti (come attrezzi e rami tagliati); è infatti dotata di **carter di protezione** della parte bassa, del motore a scoppio e dell'eventuale motore elettrico che sono fissati ad un **telaio in tubolare di acciaio** estremamente robusto.

ENG

The **Octopussy classic** is designed to meet the need for sturdy device protection during building or gardening work against the risk of falling objects (such as tools or cut branches); it is equipped with **protective guards** around the lower section, the combustion engine and the electric motor (if included), which are fastened to an extremely strong **tubular steel frame**.

ESP

**Octopussy classic** ha sido desarrollada para responder al requerimiento de solidez y protección de los dispositivos previstos para aplicaciones en construcciones o viveros de plantas y flores, en los que existe el peligro de daños derivados de caídas accidentales de objetos (tales como herramientas y ramas cortadas); en efecto, está provista de **cárteres de protección** de la parte baja, del motor de explosión y del eventual motor eléctrico, los que están fijados a un **bastidor en tubular de acero** extremadamente robusto.

FRA

**Octopussy Classic** a été réalisée pour répondre aux besoins de solidité et de protection des dispositifs utilisés dans les travaux de construction ou de jardinerie et durant lesquels subsiste le danger d'endommagements dus à la chute accidentelle d'objets (comme les outils et les branches coupées). En effet, elle est équipée de **carter de protection** de la partie basse, du moteur à explosion et du moteur électrique éventuel qui sont fixés à un **châssis en tubulaires en acier** extrêmement robuste.

robusta e protetta

sturdy and protected

robusta y protegida

robuste et protégée

**OIL & STEEL**  
www.oilsteel.com

# octopussy<sup>1401</sup> classic

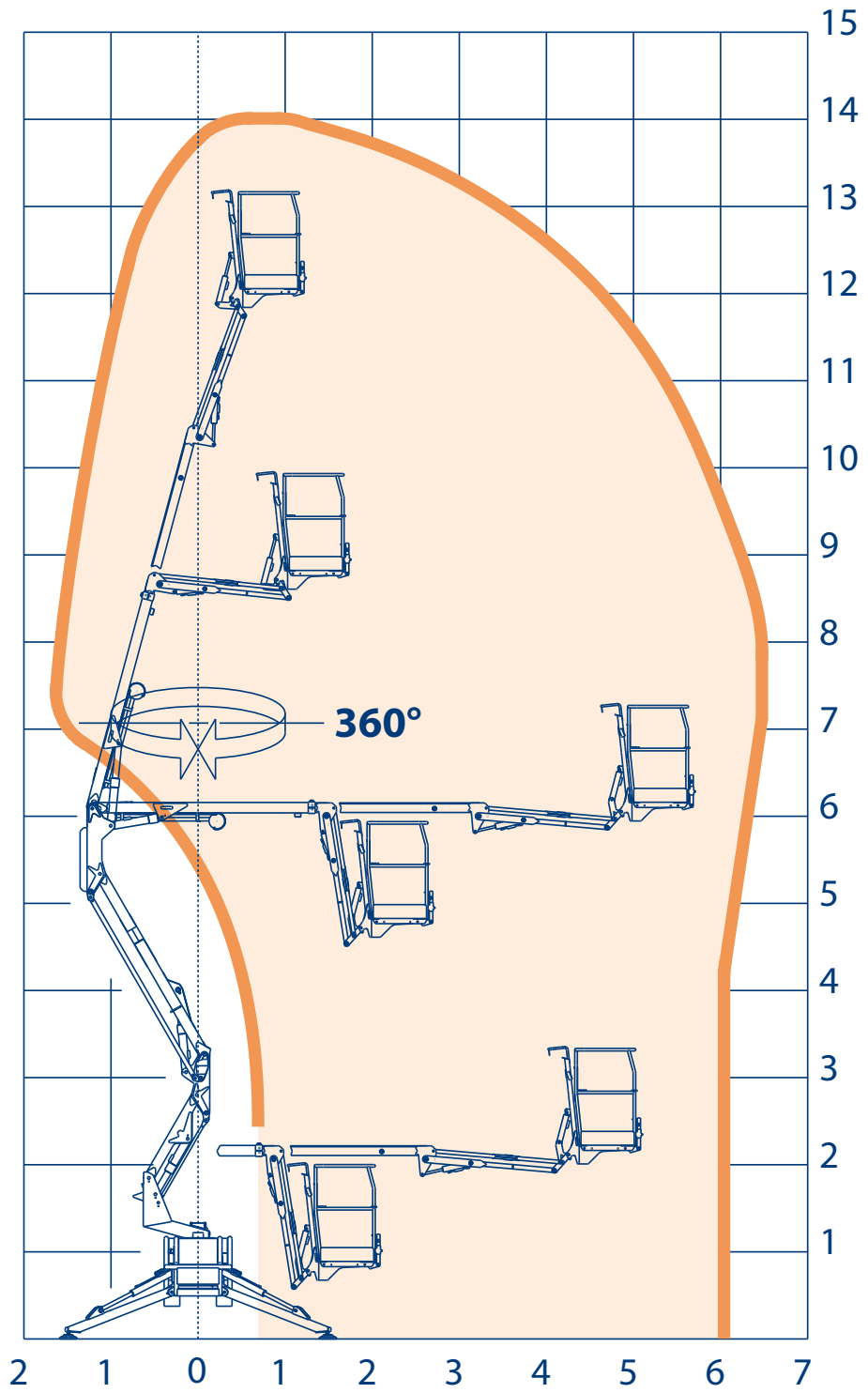

120 kg

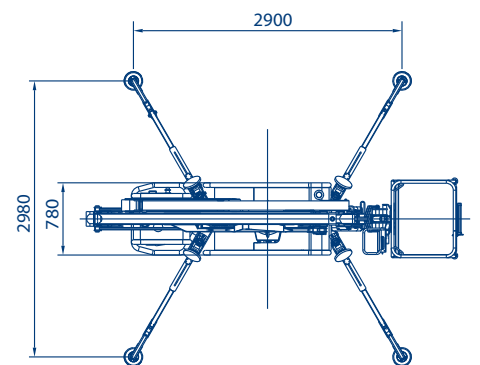
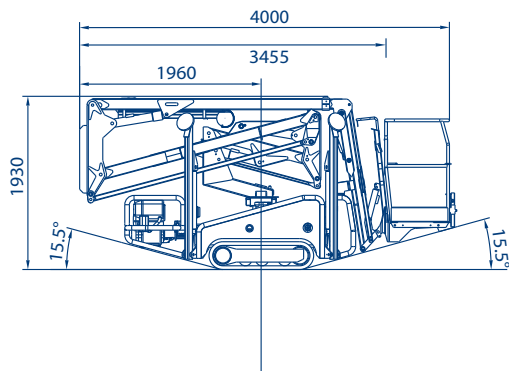



dati tecnici / specifications  
 datos técnicos / caractéristiques techniques

	14 m
	12 m
	6,5 m
	360°
	850x700x h1100 mm alluminio 850x700x h1100 mm aluminium 850x700x h1100 mm aluminio 850x700x h1100 mm aluminium
	idraulici hydraulic hidráulico hydrauliques
	120 kg / 1 operatore 120 kg / 1 operator 120 kg / 1 operario 120 kg / 1 opérateur
	1930 mm
	3455 mm
	780 mm
	honda monocilindrico silenzioso single-cylinder noiseless honda honda monocilindrico silenciado honda monocylindrique avec silencieux
	cingolata 1,5 km/h tracked 1,5 km/h oruga 1,5 km/h sur chenilles 1,5 km/h
	ribaltabili a discesa idraulica lowerable hydraulic descent repegables de bajada hidraulica escamotables à descente hydraulique
	1700 kg

octopussy<sup>1401</sup> classic



# octopussy<sup>1402</sup> classic

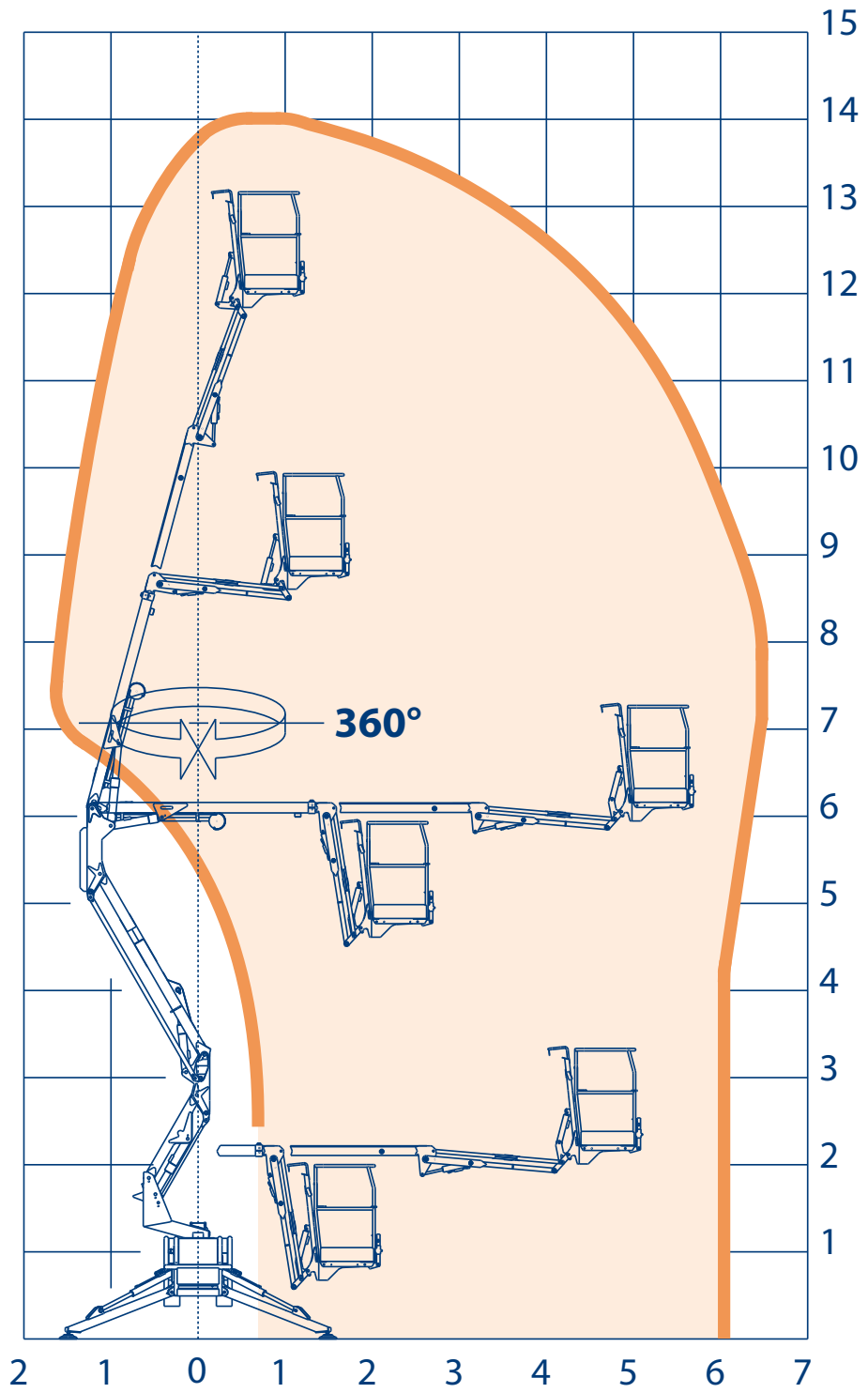

200 kg

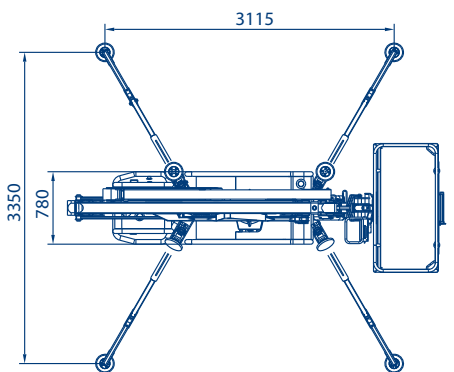
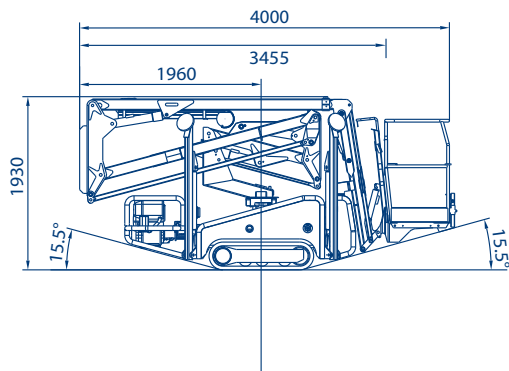



dati tecnici / specifications  
 datos técnicos / características técnicas

	14 m
	12 m
	6,5 m
	360°
	1400x700x h1100 mm 1400x700x h1100 mm 1400x700x h1100 mm 1400x700x h1100 mm
	idraulici hydraulic hidráulico hydrauliques
	200 kg / 2 operatori 200 kg / 2 operators 200 kg / 2 operarios 200 kg / 2 opérateurs
	1930 mm
	3455 mm
	780 mm
	honda monocilindrico silenzioso single-cylinder noiseless honda honda monocilindrico silenciado honda monocylindrique avec silencieux
	cingolata 1,5 km/h tracked 1,5 km/h oruga 1,5 km/h sur chenilles 1,5 km/h
	ribaltabili a discesa idraulica lowerable hydraulic descent repegables de bajada hidraulica escamotables à descente hydraulique
	1850 kg

octopussy<sup>1402</sup> classic



i dati tecnici possono essere aggiornati senza preavviso  
technical data can be revised without prior notice  
reservado el derecho de modificaciones  
les données techniques peuvent être modifiées sans preavis



**Member**

**OIL&STEEL spa**  
via G. Verdi 22  
41018 S. Cesario sul Panaro  
Modena Italy  
tel +39 059 936811  
fax +39 059 936413

**PM OIL&STEEL UK Ltd**  
2250 Kettering Parkway  
Kettering Venture Park  
Kettering, Northants NN15 6XR  
United Kingdom  
ph +44 (0) 1536 411284  
fax +44 (0) 870 9509252

**OIL&STEEL IBERICA sl**  
CTRA NATIONAL III 339  
46190 Riba-Roja del Turia  
Valencia Espana  
tel +34 902 636778  
fax +34 902 636779

**OIL&STEEL France sarl**  
2 Rue A. Fresnel  
69680 Chassieu  
France  
tel +33 0 478291736  
fax +33 0 472797703

***OIL & STEEL***  
**www.oilsteel.com**

*OIL&STEEL is a company of PM GROUP*

